



# Real Time Ethernet VARAN Bus

## VARAN - Versatile Automation Random Access Network

The VARAN bus system meets all requirements of a modern industry network optimized for machine automation. It stands out with speed, openness, high availability and optimized real-time performance. The VARAN bus is based on standard Ethernet technology. The protocol is implemented completely in the hardware, whereby the burden on the control CPU is

reduced. All messages are confirmed and immediately repeated in the event of an error. All data is therefore valid at the end of the bus cycle. The entire bus is seen as a 4 GB memory area, in which each client is assigned a defined memory space. The control CPU can therefore access each station with simple memory read and write instructions.

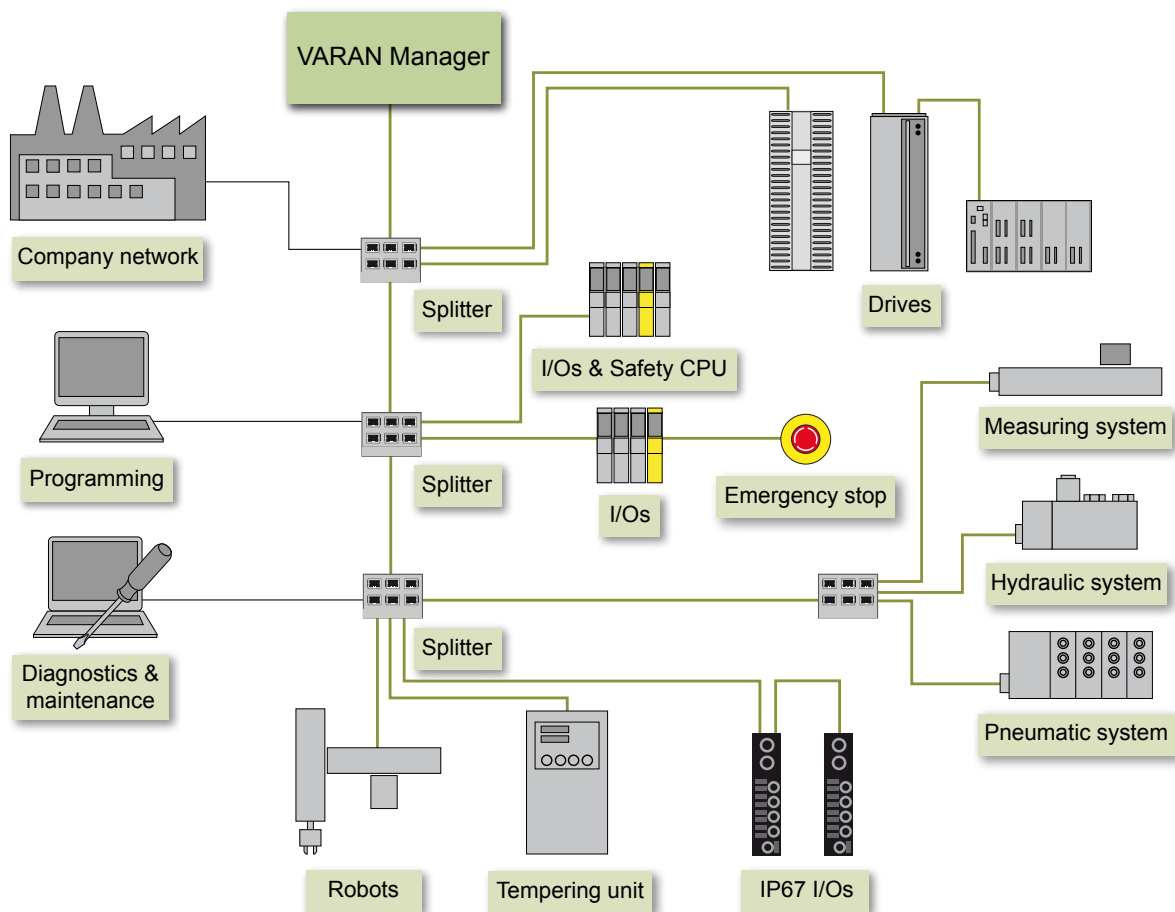

### Flexible Bus Structure

Principally, any combination of line, star and tree structures is possible. Distributors, so-called VARAN splitters, are used to build tree and star structures. The VARAN splitter distributes the

data packets to all output ports and shields the network from undesired access. The splitter function can be integrated into all clients.

## Highlights at a Glance

### ■ **High data security and error tolerance**

Unacknowledged messages are repeated within the same bus cycle

### ■ **Hard real-time**

Cycle times < 100  $\mu$ s, jitter < 100 ns - each command is immediately confirmed by the recipient

### ■ **Flexible Network Topology**

Modular machine structures: star, line and tree topologies can be combined as desired

### ■ **Economic**

On the price level of a field bus connection through the use of inexpensive standard components for the manager and client

### ■ **Open Standard**

The VARAN bus is an open standard and manufacturer-independent. The rights to the technology are held by an independent organization, the VARAN BUS USER ORGANIZATION (VNO).

## Facts that Convince

### ■ **Dynamic**

Small frames (128-byte payload and low overhead)

### ■ **Direct access**

Fast asynchronous direct access during the bus cycle

### ■ **Multi-manager capability**

Networking of several autonomous systems

### ■ **Automatic addressing**

Minimizing network administration costs

### ■ **Protocol is implemented completely in the hardware**

No additional load on the CPU

### ■ **Hot plug capability**

Modules can be added or removed during active operation.

### ■ **Electronic type label**

Clear identification of each bus client

### ■ **Tunneling of standard Ethernet**

Standard TCP/IP communication is also possible for the shortest cycle times

### ■ **Synchronization over PLL**

Distributed clocks according to IEEE 1588 are not required

### ■ **Simple implementation**

Even in small sensors and actuators

### ■ **Bus and power supply in a single cable**

Simple signal and power connection through the VNO certified connectors and hybrid cables

### ■ **CANopen® mapping on the VARAN bus**

Simple connection of existing CANopen® devices

### ■ **Simple analysis and servicing**

With comfortable diagnostic and service tools

## VARAN Bus Basics

With the VARAN bus, the requirements for hard real time control are combined with those of automation and implemented using Ethernet technology. Collisions are avoided through the use of the Manager-Client principle. VARAN Operates in hard real-time with guaranteed determinism. Cycle times under 100  $\mu$ s are possible and the jitter is below 100 ns. In addition, the VARAN bus offers the unique possibility of

asynchronous direct access. The technology is open and can be used by everyone.

In order to take full advantage of the available networking, TCP/IP communication is integrated. The VARAN bus can also, among others, transport standard Ethernet frames that are further used for the start-up and evaluation of clients.

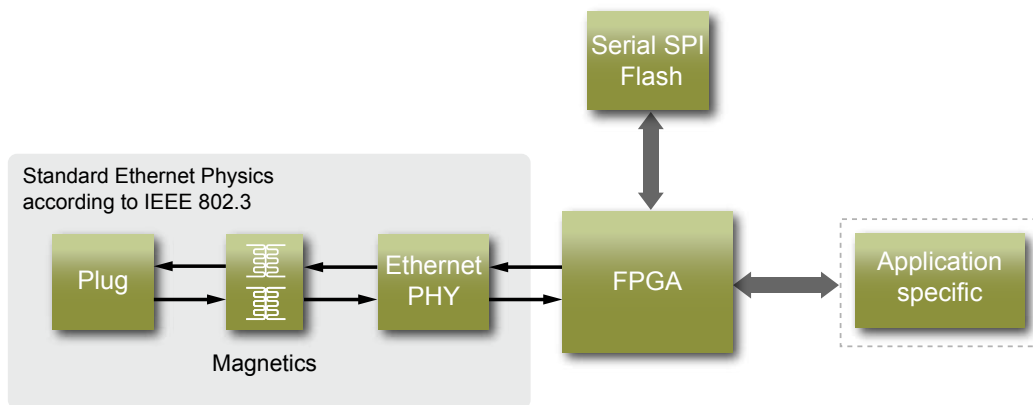

**All components of a VARAN integration**

The basic design of a VARAN implementation is identical for the manager and the client. The Ethernet physical layer is formed by the connectors, transmitters and the Ethernet PHY component. The PHY component provides auto-crossover so that standard CAT 5 cables (crossed or non-crossed) can be used. For the power

supply, a 24V DC voltage can be integrated through the use of hybrid cables. Actuators and sensors are connected using a single connector, through which, the overall size and error sources can be reduced to a minimum. Through the use of FPGAs, application-specific add-ons can be integrated.

## ■ Guaranteed Data Security

When developing VARAN, special attention was given to the validity of data. The client, immediately confirms every instruction received from the manager. If the client does not answer within the specified timeout period, or the answer is erroneous, the manager immediately repeats the instruction without incriminating the message counter until a valid response is received. The

client thereby recognizes the instruction as a repetition. This procedure guarantees that all data is consistent at the end of the cycle. The constant testing of data validity - even with cycle times smaller than 100  $\mu$ s - is only possible using small VARAN data frames (1-128 Bytes). The IEEE 1588-defined clock synchronization of the bus clients is not required for the VARAN bus.

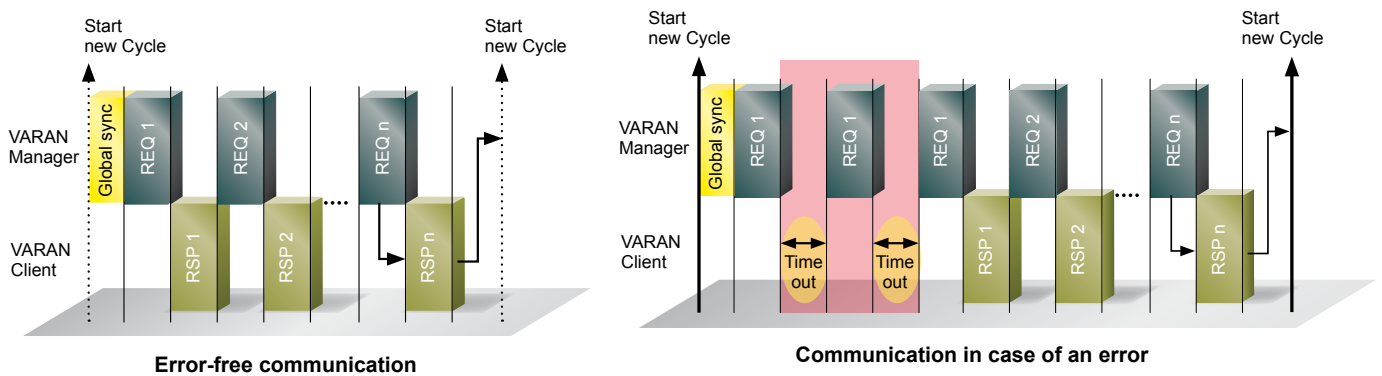

## ■ Bus Cycle Distribution

At the start of each bus cycle, the manager sends a global SYNC instruction. The isochronous real-

time objects are sent next, followed by the asynchronous objects and finally the data objects of the administration task. In the administration task, processes such as scanning for new clients or the transmission of standard Ethernet packets are executed. The asynchronous direct access interrupts the running tasks for less than 25  $\mu$ s to perform a client update during the bus cycle.

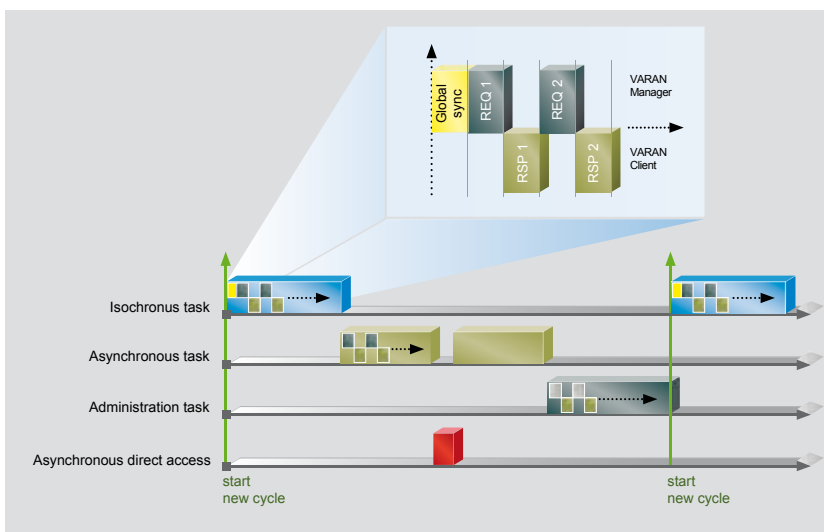

**Communication timing: VARAN enables asynchronous direct access to bus clients at any time.**

## Access Times in the $\mu\text{s}$ Range

The update times are an essential aspect of real time Ethernet networks. When writing to 16 I/Os (instruction length of 2 Bytes), the VARAN bus has an update time of 2  $\mu\text{s}$ . Drives, each with 16-byte actual and set values, can be processed

with a single read/write instruction in 5  $\mu\text{s}$ . These times increase by 1  $\mu\text{s}$  per distributor node. To obtain short update and bus cycle times, a tree structure is therefore recommended.

## Performance Data

Bus cycle time	< 100 $\mu\text{s}$	
Jitter	< 100 ns	
Isochronous access time	1-byte r/w	2.18 $\mu\text{s}$
	16-byte r/w (1 Drive)	5.05 $\mu\text{s}$
Asynchronous direct access	128-byte r/w	< 25 $\mu\text{s}$
Portable to Gigabit Ethernet without protocol changes		

## Minimal Latency Time

For read and subsequent write access to a bus device, the latency period is maximal 1.5 bus

cycles - including the processing of I/O data by the CPU.

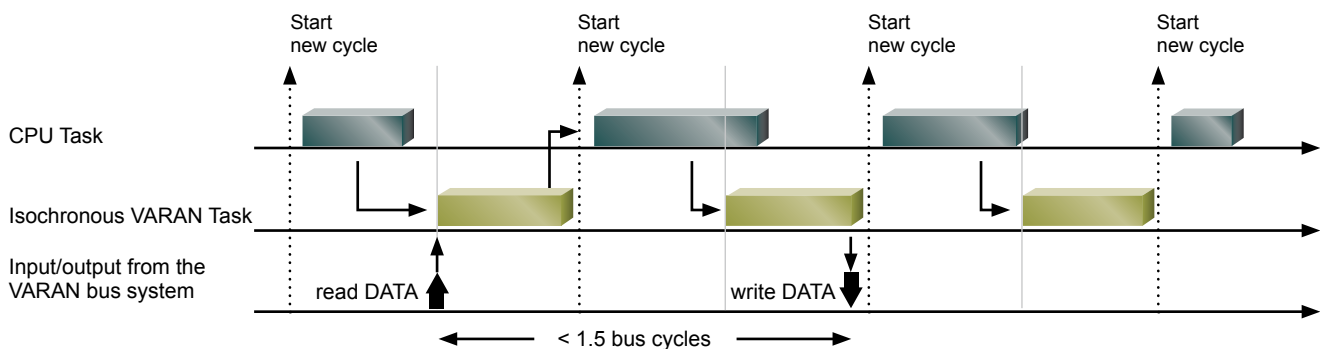

## ⚡ Electronic Identification Plate

All modules with a VARAN connection are assigned an electronic identification plate containing the device-specific data:

- Vendor ID
- Device ID
- License number

Modules with an invalid identification plate or an invalid license are deactivated. The bus system is therefore protected against undesired clients.

It is also possible to add customer-specific files in the VARAN client. The module description, for example, can be saved in the client as a PDF and accessed via the VARAN service tool or directly from the control application.

## ➡ The VARAN Bus in Detail

One controls all: the VARAN manager administrates the entire bus memory area, which can support up to 65,280 clients. Each client is assigned its own linear address space of 65,536 bytes during the start-up phase.

In principle, the information exchange is based on two operations: “Write the following data to address x” and “Read the following number of bytes starting from address x”.

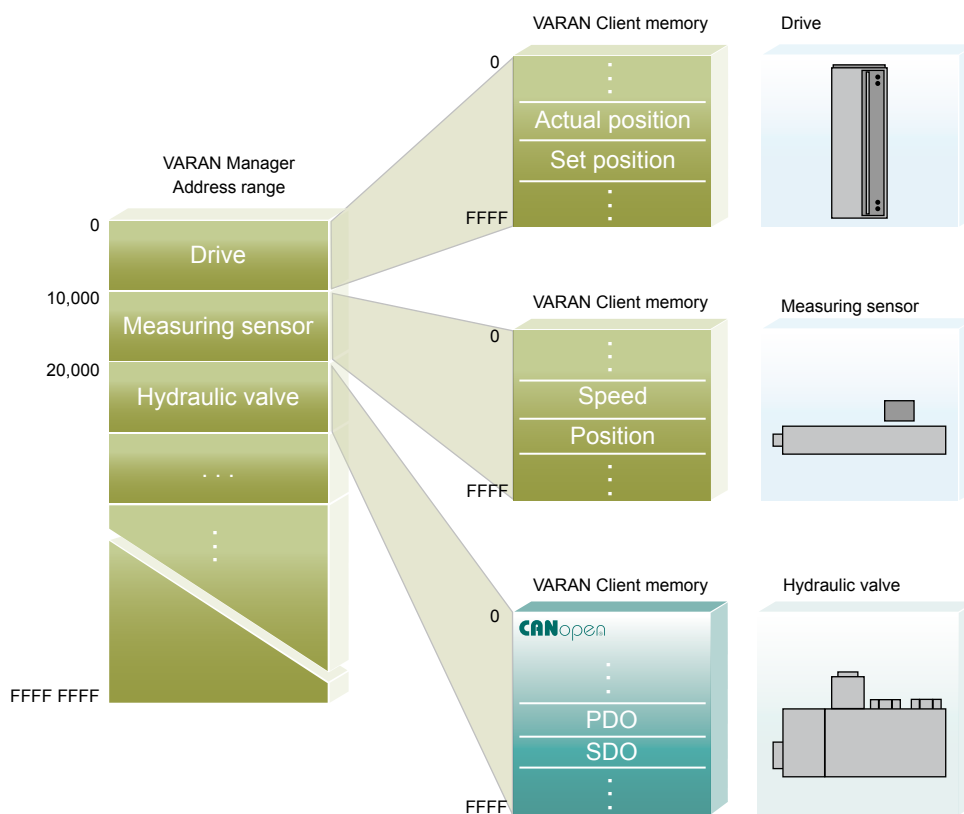

**Data exchange over the entire address range**

## ▣ The VARAN Manager

Each data transfer is initiated and centrally managed by the VARAN manager exclusively. All protocol-specific tasks of the VARAN manager are processed in the FPGA, which reduces the load on the control CPU.

The manager consists of several areas with various priority levels: Direct Access (DA), Asynchronous (ASYN), Isochronous (ISO).

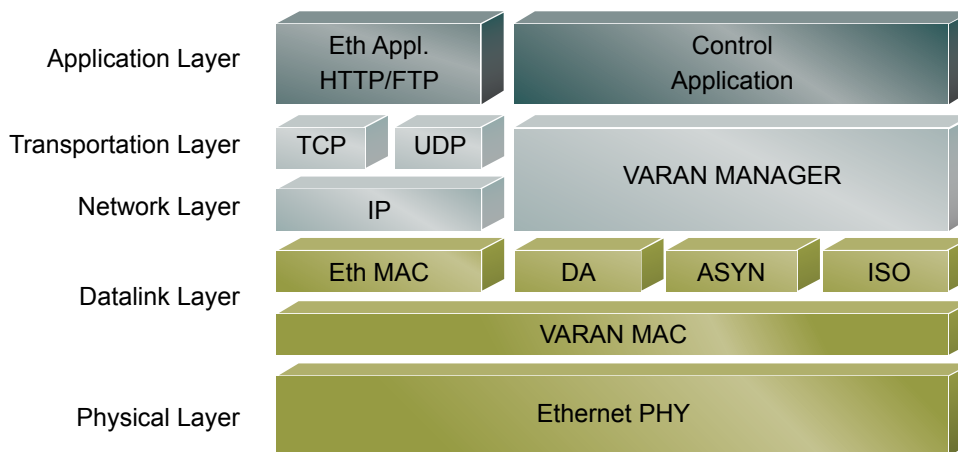

The VARAN manager according to the layer concept of the OSI model.

## ▣ VARAN Instruction Overview

The VARAN Bus design is intentionally simple, whereby the entire instruction set is reduced to a few commands.

These two instructions can be combined into one **Memory Read/Write** instruction, whereby the overhead is reduced further.

- **Memory Read:**

Reads data from the memory of a client. This instruction contains the start address and the number of bytes to be read.

- **Global Write:**

All bus clients are addressed simultaneously. This instruction is used to synchronize all bus clients and to perform a global reset.

- **Memory Write:**

Writes data to the memory of a bus client. The write command contains the start address and the data to be written. The client sends a confirmation.

- **Foreign Package Request/Response:**

Initiates the transportation of foreign data packets (TCP/IP, safety or other protocols) through the VARAN bus system.

## Multi-Manager Structure

Several VARAN systems can be cascaded into a complete synchronous network through a primary VARAN Manager. A multi-manager

structure is thereby generated. This allows several machines to exchange data with one another. The jitter is below 100 ns.

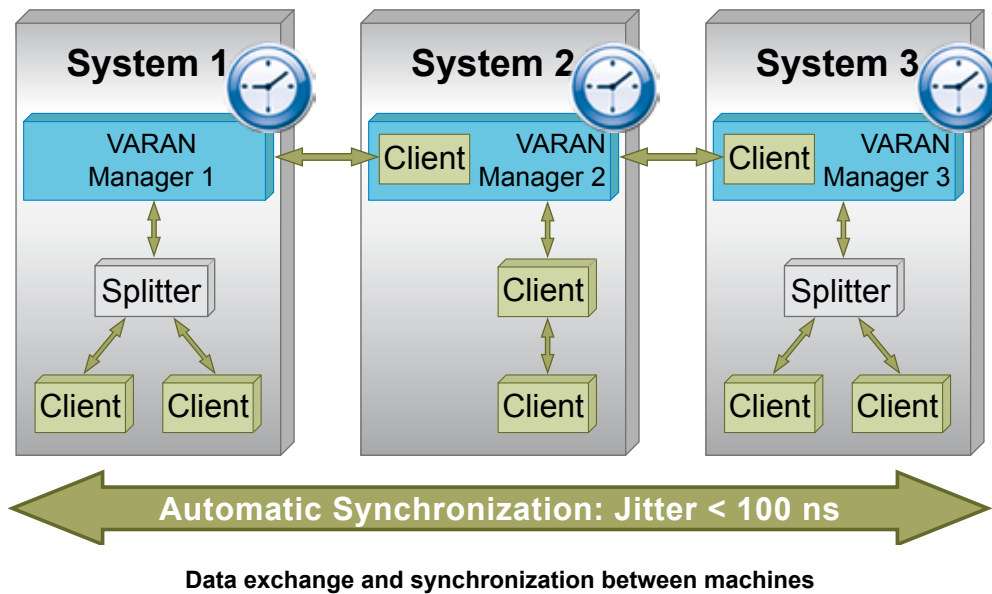

## Connection to a Company Network

The Ethernet communication from the office world is controlled by the VARAN manager. Each client with a standard IP port is detected and queried during the administration task for Ethernet frames that should be transmitted. Up-

coming IP data is then transmitted to all IP nodes (IP tunneling). Unauthorized access cannot affect the real-time communication. Additional security installations such as firewalls are not required to connect with a company network.

## Integrated Safety

In the past, complex, discrete wiring was used for safety circuits. Through the use of VARAN Bus technology, the costs for safety technology are drastically reduced. The safety-relevant signals are thereby transmitted simultaneously with

the process data over the real-time Ethernet bus system. The VARAN protocol serves as the container for the Safety telegram and operates according to the "Black Channel" principle.

The bus system is excluded from the Safety considerations, whereby the unrestricted trans-

mission of Safety data over the back plane or other transport media is possible.

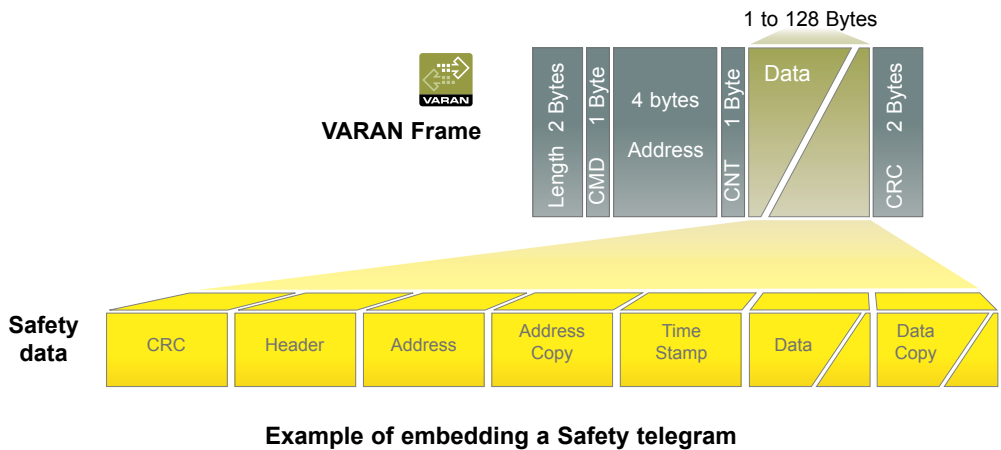

With VARAN, central and decentral Safety solutions can be implemented as desired. With multi-manager networks, Safety signals can be trans-

mitted over several machines and are therefore provided to the entire production line.

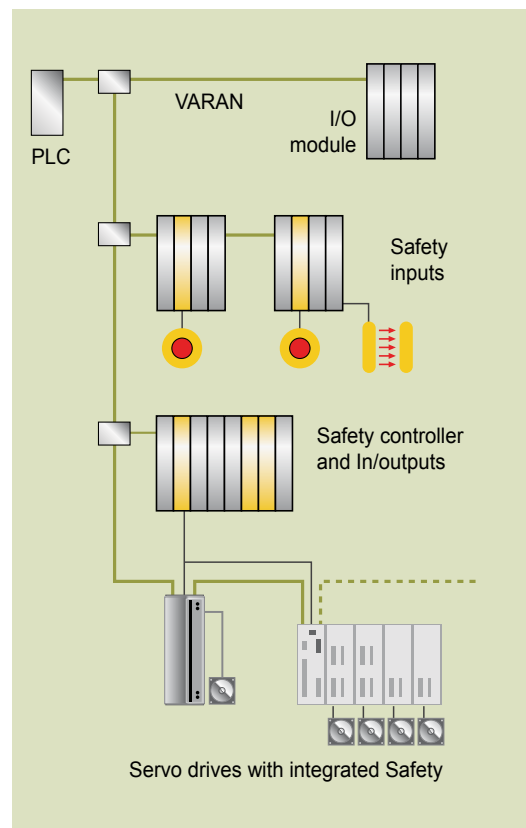
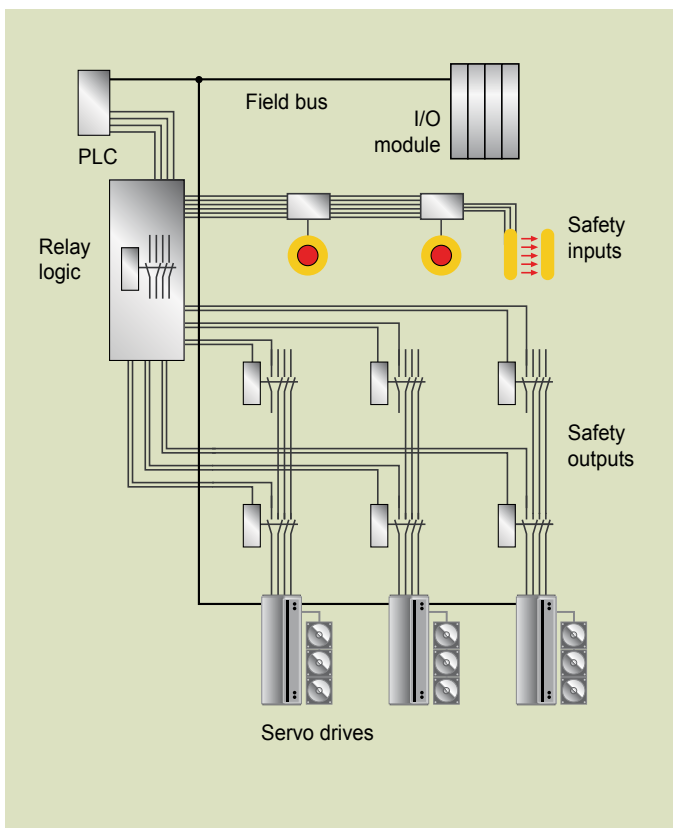

## ❑ Connection Technology

Because real time Ethernet in the industrial automation branch demands high quality and robustness from connectors and cables, the VNO has worked intensively to optimize connection technology.

For the IP20 area, the Harting RJ45 Industrial is certified. This connector is tested for its industrial suitability.

To meet the demands for low-cost machine wiring, solutions that require only one connector were developed for the connection of field bus devices in the IP67 world. For bus clients with 24V and a maximum current consumption of 2 A, the 8-pin M12 connector from Phoenix Contact is



**Series HC.26**

**M12**

**RJ45 industrial**

used. For high power devices (up to 10 A) and separate power supply requirements, a new „8+4 Power/Ethernet connector“ was developed by Tyco Electronics. Corresponding hybrid cables are available for both variants.



[www.varan-bus.net](http://www.varan-bus.net)



**VARAN BUS USER ORGANIZATION Branch Office**  
Buermooser Straße 10 | 5112 Lamprechtshausen | Austria

---

Tel.: +43/62 74/4321-0 | Fax: +43/62 74/4321-18  
[info@varan-bus.net](mailto:info@varan-bus.net)